

+ DIMENSIONI

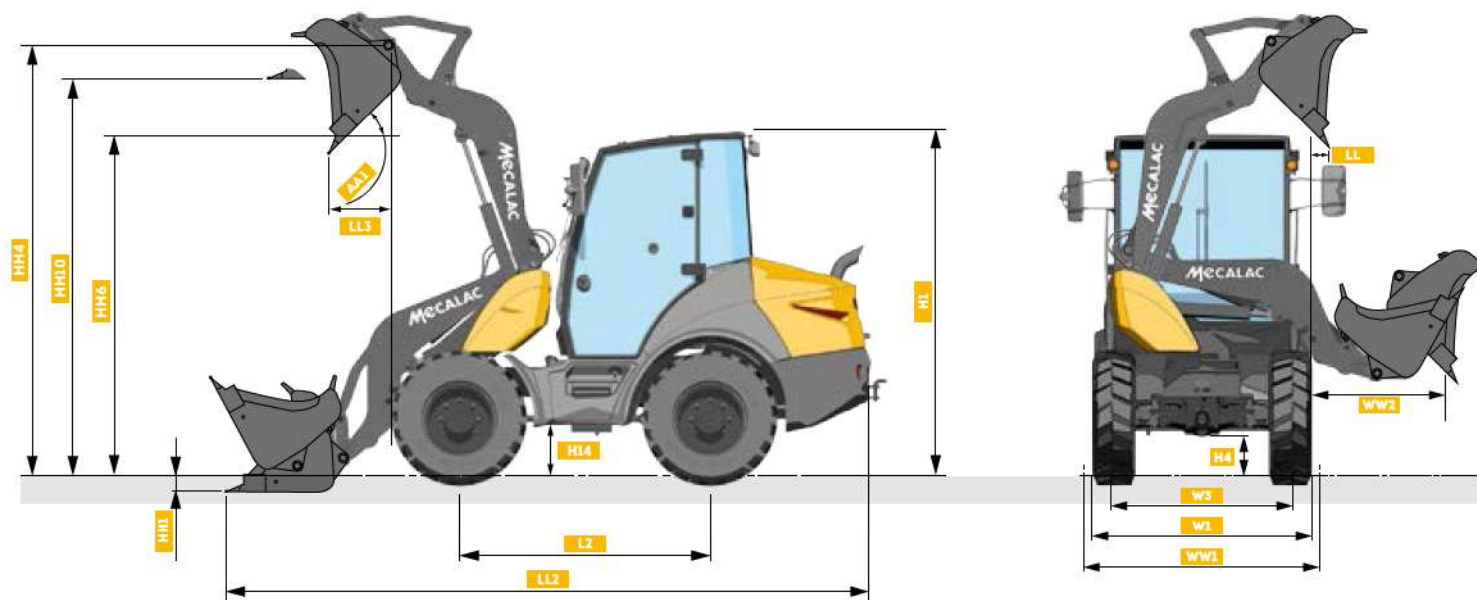

DIMENSIONI MACCHINA		AS600	AS750	AS850	AS1000
BENNE		STD. 0.6 m ³	STD. 0.75 m ³	STD. 0.85 m ³	STD. 1.0 m ³
AA1	Angolo di ribaltamento max	39°	43°	45°	45°
H1	Altezza fuori tutto	2495 mm	2495 mm	2830 mm	2830 mm
H4	Luce libera dal suolo del ponte / scatola del cambio	330 mm	330 mm	390 mm	390 mm
H4	Luce libera dal suolo dell'albero di trasmissione	380 mm	380 mm	440 mm	440 mm
HH0	Profondità di carico/scarico in negativo	100 mm	70 mm	130 mm	150 mm
HH4	Perno di rotazione della benna	3275 mm	3300 mm	3500 mm	3500 mm
HH6	Altezza di scarico all'altezza max di sollevamento con angolo di ribaltamento di 45°	2600 mm	2560 mm	2640 mm	2650 mm
HH0	Altezza di carico al fondo della benna	2980 mm	3105 mm	3190 mm	3191 mm
L2	Interasse	1790 mm	1870 mm	1980 mm	1980 mm
LL	Larghezza di scarico laterale all'altezza max di sollevamento con angolo di ribaltamento di 45°	25 mm	290 mm	730 mm	730 mm
LL2	Lunghezza fuori tutto	4944 mm	5010 mm	5600 mm	5600 mm
LL3	Larghezza di scarico all'altezza max di sollevamento con angolo di ribaltamento di 45°	415 mm	650 mm	940 mm	940 mm
W1	Larghezza con pneumatici	max. 1660 mm std. 1580 mm	max. 1770 mm std. 1690 mm	std. 1950 mm	std. 1990 mm
W3	Scartamento tra le ruote	1290 mm	1400 mm	1590 mm	1660 mm
WW1	Larghezza sopra la benna	1700 mm	1860 mm	1950 mm	2100 mm
WW2	Larghezza di scarico all'altezza di sollevamento minima	1040 mm	1225 mm	1470 mm	1470 mm

+ DIMENSIONI

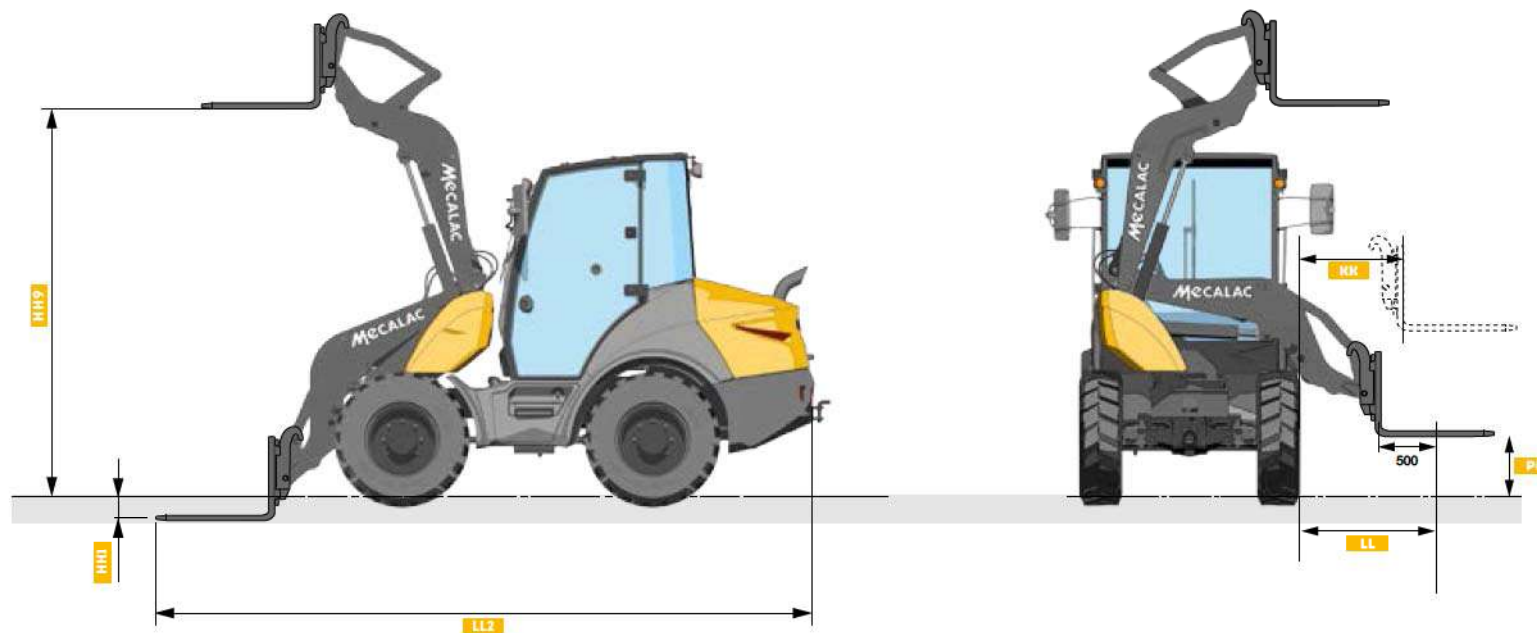

DIMENSIONI MACCHINA		AS600	AS750	AS850	AS1000
SOLLEVA-PALLET					
H#H	Profondità di carico/scarico in negativo	40 mm	150 mm	220 mm	220 mm
H#P	Altezza di sovraccarico all'altezza max di sollevamento	3003 mm	2780 mm	3170 mm	3170 mm
KK	Massima larghezza di carico sul lato	762 mm	865 mm	1010 mm	1010 mm
L	Larghezza laterale dal centro del carico all'altezza di sollevamento minima	1122 mm	1225 mm	1420 mm	1420 mm
LL2	Lunghezza fuori tutto	5546 mm	5700 mm	6160 mm	6160 mm
PP	Altezza minima sul lato	560 mm	855 mm	380 mm	380 mm

+ DIMENSIONS

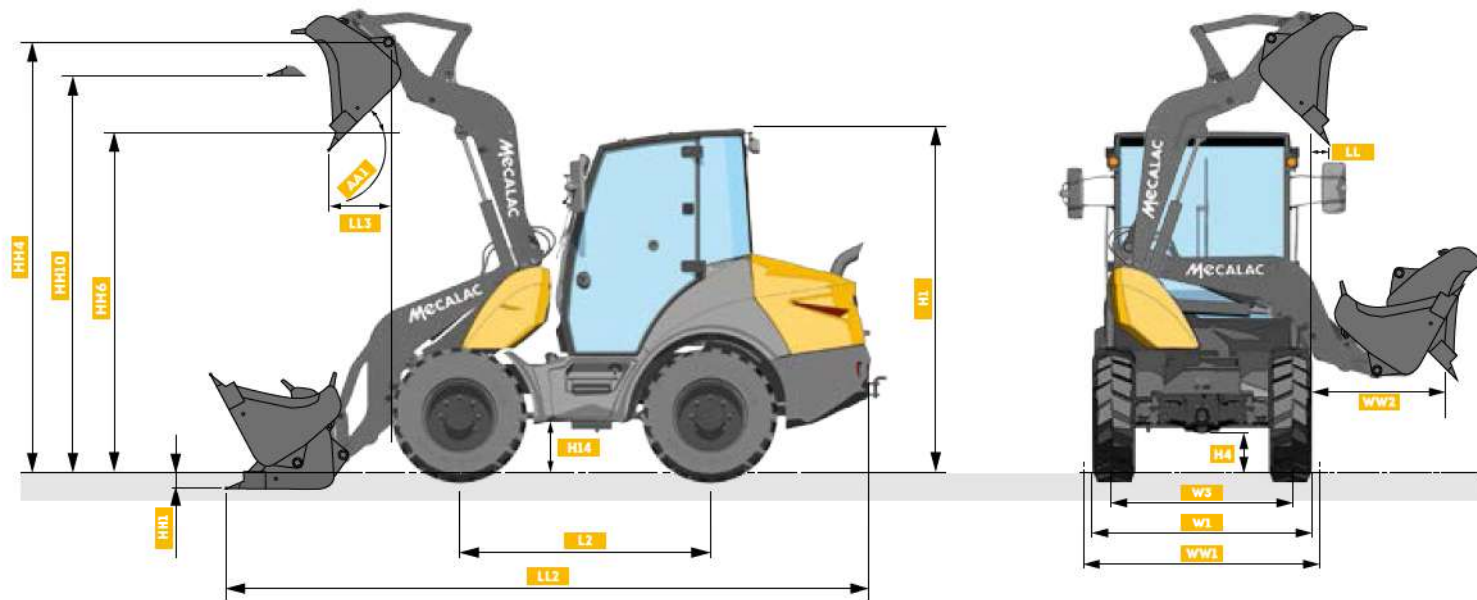

DIMENSIONNEL MACHINE		AS600	AS750	AS850	AS1000
GODETS		STD. 0.6 m³ (0.78 yd³)	STD. 0.75 m³ (0.98 yd³)	STD. 0.85 m³ (1.11 yd³)	STD. 1.0 m³ (1.3 yd³)
AA1	Angle de basculement max	39°	43°	45°	45°
H1	Hauteur hors tout	2495 mm (8'2")	2495 mm (8'2")	2830 mm (9'3")	2830 mm (9'3")
H4	Garde au sol du pont / boîte de vitesse	330 mm (1'1")	330 mm (1'1")	390 mm (1'3.35")	390 mm (1'3.35")
H44	Garde au sol de l'arbre de transmission	380 mm (1'2.96")	380 mm (1'2.96")	440 mm (1'5.32")	440 mm (1'5.32")
H60	Profondeur de plongée	100 mm (0'3.9")	70 mm (0'2.7")	130 mm (0'5.11")	150 mm (0'5.9")
H44	Axe de pivotement du godet	3275 mm (10'9")	3300 mm (10'9.9")	3500 mm (11'5")	3500 mm (11'5")
H6	Hauteur de déversement de levage max à un angle de basculement de 45°	2600 mm (8'6")	2560 mm (8'5")	2640 mm (8'7")	2650 mm (8'8")
H60	Hauteur de chargement au fond du godet	2980 mm (9'9")	3105 mm (10'2")	3190 mm (10'5")	3191 mm (10'5")
L2	Empattement	1790 mm (5'10")	1870 mm (6'1")	1980 mm (6'5")	1980 mm (6'5")
LL	Largeur de déversement de levage max à un angle de basculement de 45°	25 mm (0'9.8")	290 mm (0'11.4")	730 mm (2'4")	730 mm (2'4")
LL2	Longueur hors tout	4944 mm (16'2")	5010 mm (16'5")	5600 mm (18'4")	5600 mm (18'4")
LL3	Largeur de déversement de levage max à un angle de basculement de 45°	415 mm (1'4")	650 mm (2'1.59")	940 mm (3'1")	940 mm (3'1")
W1	Largeur avec pneus	max. 1660 mm (5'5") std. 1580 mm (5'2")	max. 1770 mm (5'9") std. 1690 mm (5'6")	std. 1950 mm (6'4")	std. 1990 mm (6'6")
W3	Voie des roues	1290 mm (4'2")	1400 mm (4'7")	1590 mm (5'2")	1660 mm (5'5")
WW1	Largeur au-dessus du godet	1700 mm (5'6")	1860 mm (6'1")	1950 mm (6'4")	2100 mm (6'10")
WW2	Largeur de déversement à la hauteur de levage minimale	1040 mm (3'5")	1225 mm (4'0.22")	1470 mm (4'9")	1470 mm (4'9")

+ DIMENSIONS

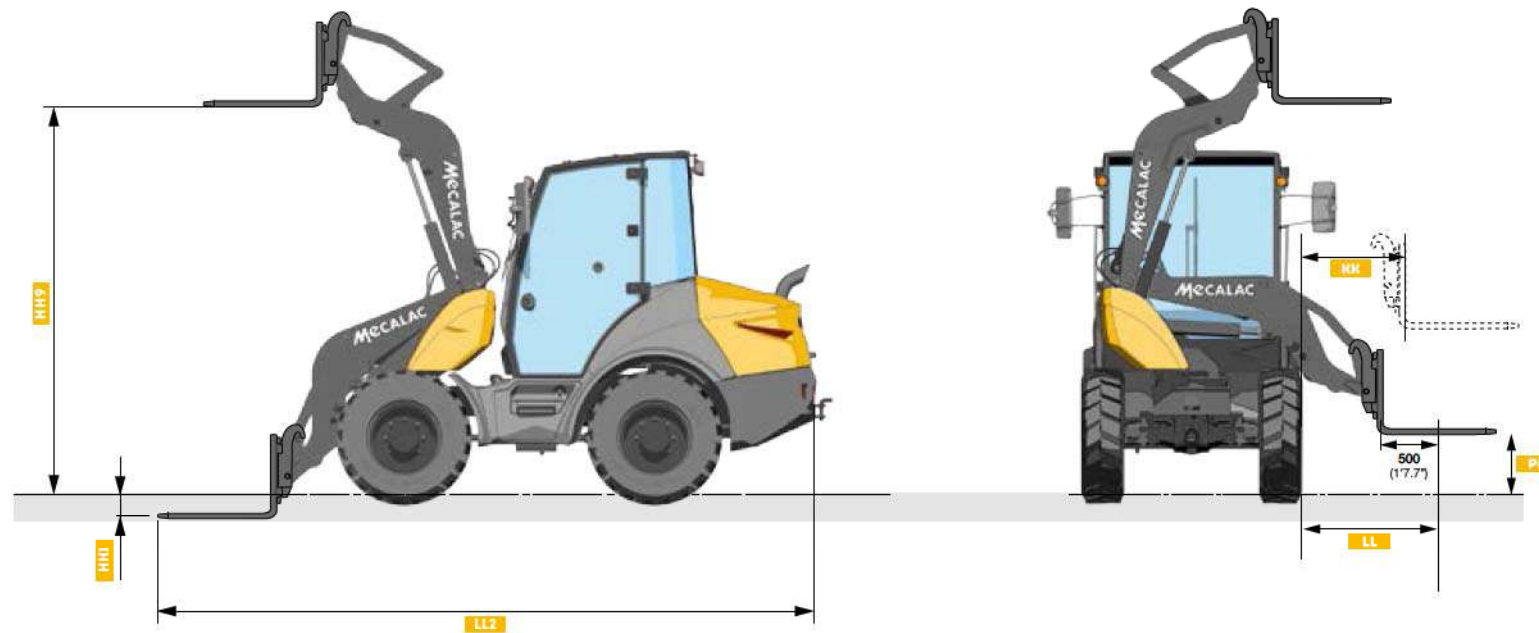

DIMENSIONNEL MACHINE		AS600	AS750	AS850	AS1000
LÈVE-PALETTE					
H#H	Profondeur de plongée	40 mm (0'1.6")	150 mm (0'6")	220 mm (0'8.6")	220 mm (0'8.6")
H#P	Hauteur de la surcharge de levage maximale	3003 mm (9'10")	2780 mm (9'1.45")	3170 mm (12'5")	3170 mm (12'5")
KK	Largeur maximale de la charge sur le côté	762 mm (2'6")	865 mm (2'10")	1010 mm (3'10")	1010 mm (3'10")
L	Largeur latérale du centre de la charge à la hauteur de levage min.	1122 mm (3'8")	1225 mm (4'0")	1420 mm (5'6")	1420 mm (5'6")
LL2	Longueur hors tout	5546 mm (18'2")	5700 mm (18'8")	6160 mm (24'2")	6160 mm (24'2")
PP	Hauteur minimale sur le côté	560 mm (1'10")	855 mm (2'9.6")	380 mm (0'1.5")	380 mm (0'1.5")

MecALAC

AS
SERIES



AS600/750/850/1000 SERIES

AS

MecALAC



MOBILITY



STABILITY



SPACE MANAGEMENT

Switch to **THE SWING CONCEPT**

MECALAC REVOLUTIONIZES LOADING

The Mecalac Swing loader – with high efficiency and speed of action – provides top performance on all construction sites.

Its ability to simultaneously drive, maneuver and pivot is key to the high productivity. Switch to space management, mobility and stability.



AS600



AS75



WATCH THE VIDEO



AS

AS850

AS1000



SWING CONCEPT

Switch to MOBILITY

3 STEERING MODES

Urban construction sites are often congested, workspace is limited and ground conditions are often compromised. Designed around a one-piece frame with 3 steering modes as standard - 2 wheel steering, 4 wheel steering, crab - the mobility of this machine is 100% assured.

2 WHEEL STEERING



4 WHEEL STEERING



4 WHEEL CRAB STEERING



TURNING RADIUS OVER BUCKET

With 4 wheel steering, combined with the 180° swivel arm, the Mecalac Swing can perform a complete rotation on a footprint that is 20% smaller than that of a conventional loader.

SWING LOADER

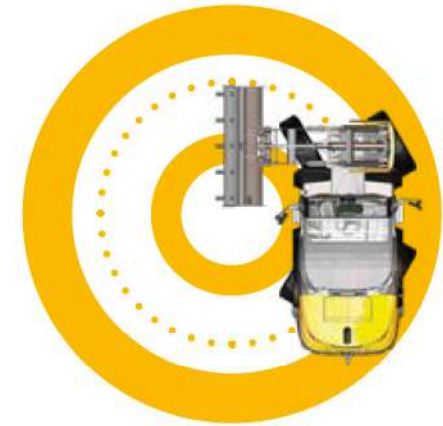

ARTICULATED LOADER





WATCH THE VIDEO





SWING CONCEPT

Switch to STABILITY

PROVEN STABILITY

Whatever is lifted by the bucket at the front, once the rear axle is locked, can be turned through 180° without any loss of steadiness. Thanks to this incredible stability in all positions and on all terrains, the Swing loader is able to radically transform the logistics of construction sites.

Whatever the circumstances, it never loses its equilibrium whether moving on site, between sites or during the various work stages, maintaining its mobility while reliably and securely overcoming any obstacles with ease. Its small turning radius ensures a very high degree of maneuverability, even on the most confined sites.

SWING LOADER

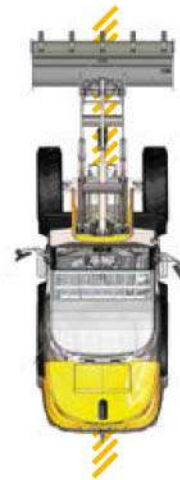

**100%
STABILITY**



**100%
STABILITY**

ARTICULATED LOADER



**100%
STABILITY**



**75%
STABILITY**



WATCH THE VIDEO





SWING CONCEPT

Switch to SPACE MANAGEMENT

MECALAC SWING, IMMEDIATE EFFICIENCY

Urban construction sites and places with limited space and time are the natural environment for the compact wheeled loader. In addition to this compactness, essential in these environments, the efficiency of a wheeled loader is determined by its loading and unloading cycles.

These cycles consist of many time consuming maneuvers that account for a large proportion of a conventional loader's working time. Taking these considerations as a starting point, the innovative Mecalac Swing loader concept was born.

The swing concept places an even greater focus on the actual operation of a wheeled loader in order to make it more efficient and more comfortable for the driver.



SWING LOADER



ARTICULATED LOADER



COMPACTNESS, EFFICIENCY

Greater benefit in operation has already been achieved by saving time in all maneuvers and avoiding unnecessary movements to optimize the use of the available space on site. The Swing loader, thanks to its arm, pivots instead of having to reposition. As a result, less time is wasted, less noise and visual nuisance are generated, less maintenance is required, and there is a lower risk of accidents and less impact on the environment. For example, a conventional loader needs 10 meters (32'8") of footprint to load a truck, the Swing only needs 5 meters (16'4").



SWING LOADER



ARTICULATED LOADER

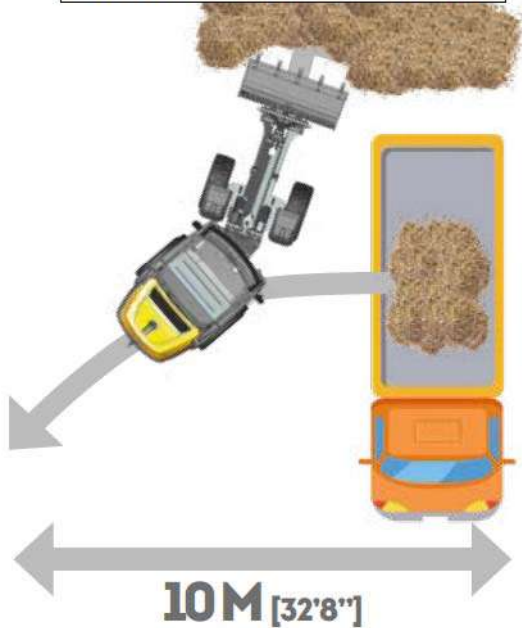

SANDING A TRENCH

In the same way, not blocking traffic while filling a trench also means time saved and disruption minimized. The unparalleled compactness of the Mecalac Swing loader allows it to dump sand in a single lane where other loaders encroach on two lanes.

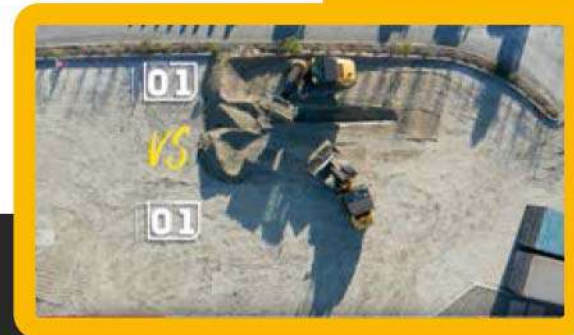

SWING LOADER

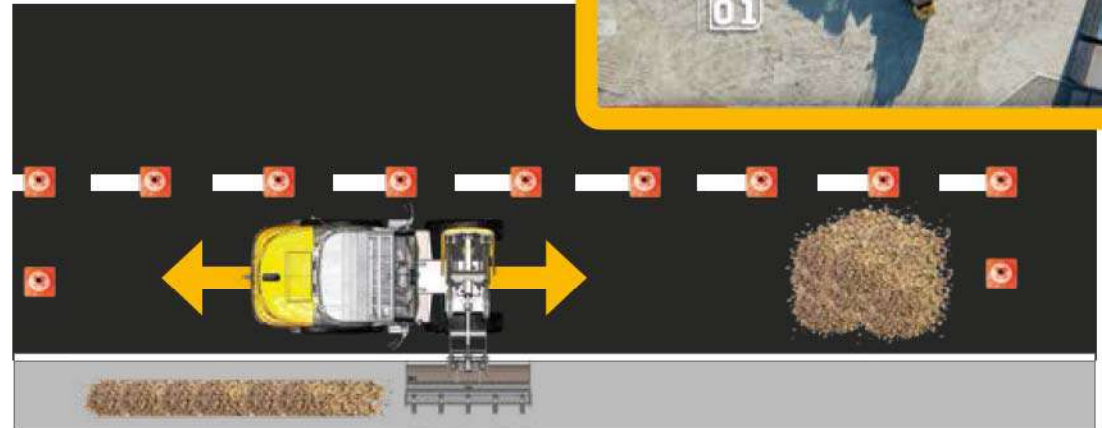

ARTICULATED LOADER

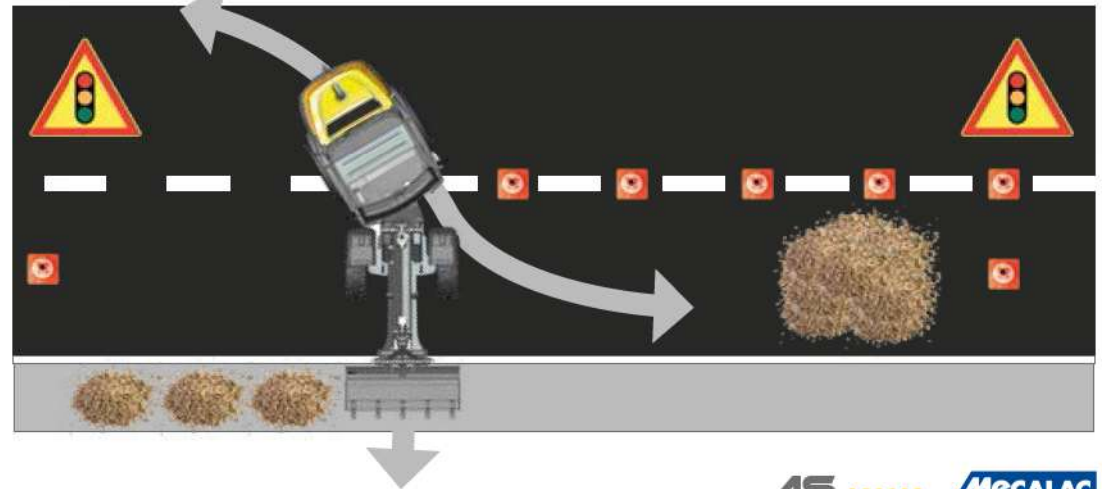



SWING CONCEPT

Switch to **VERSATILITY**

180° PROFITABLE, SWIVELLING IS MORE EFFICIENT THAN STEERING – THIS MULTIPLIES WITH EACH ADDITIONAL ATTACHMENT

No matter whether standard attachments such as bucket, forks and loading hook or individual attachments like concrete mixing buckets and earth auger. In addition to the hydraulic series quick-coupler, the electro-hydraulic quick-coupler with two-hand control has been a standard for more than 10 years. Maximum operational safety and maximum comfort are absolutely imperative for Mecalac. Boom suspension, a second auxiliary hydraulic circuit, permanent function on auxiliary hydraulic circuit etc. can be implemented upon customer's request. An optional 120 litres high-performance hydraulics is available (AS1000), e.g. for flail mowers and asphalt milling attachments.





MOBILITY



STABILITY



**SPACE
MANAGEMENT**



VERSATILITY





AS600 - AS750

AS600/750 CAB

2 doors

ENGINE

AS600: Deutz TCD 2.2 L3 - 36.4 kW / 49.5 hp

AS750: Deutz TCD 2.2 L3 - 45 kW / 61 hp

LIGHTS

LED rear lights

HYDRAULICS

AS600: Standard 40 l/min (10.6 gal/min) /
230 bar (3336 psi)

AS750: Standard 60 l/min (15.9 gal/min) /
230 bar (3336 psi)

BOOM TYPE

Boom AS600/750

KINEMATIC AND QUICK-COUPLER

"P kinematic" (Parallel)
Kat II Z

BUCKET CAPACITY

AS600: 600 liters

AS750: 750 liters

WHEELBASE

AS600: 1790 mm (5'10")

AS750: 1870 mm (6'1")

STANDARD WIDTH

AS600: 1700 mm (5'7")

AS750: 1860 mm (6'1")

NOTE: METRIC MEASUREMENTS ARE THE CRITICAL VALUES

- 1 Litre = 0.26417 US Liquid Gallons

- 1 Litre = 0.21997 Imperial Liquid Gallons



AS850-AS1000

AS850/1000 CAB

2 doors

ENGINE

AS850: Deutz TCD 2.2 L3 / 55.4 kW / 75 hp
Torque 280 Nm (206.5 ft.lbf)

AS1000: Deutz TCD 2.9 L4 / 55.4 kW / 75 hp
High-torque 375 Nm (276.6 ft.lbf)

LIGHTS

LED rear lights

HYDRAULICS

AS850: 84 l/min (22.2 gal/min) /
230 bar (3336 psi)

AS1000: 84 l/min (22.2 gal/min) /
230 bar (3336 psi)
High flow option

BOOM TYPE

New generation

KINEMATIC AND QUICK-COUPLER

"Z kinematic"
Mecalac Quick-coupler

BUCKET CAPACITY

AS850: 850 liters
AS1000: 1000 liters

WHEELBASE

1980 mm (6'5")

STANDARD WIDTH

AS850: 1950 mm (6'5")
AS1000: 2100 mm (6'11")

NOTE: METRIC MEASUREMENTS ARE THE CRITICAL VALUES

- 1 Litre = 0.26417 US Liquid Gallons
- 1 Litre = 0.21997 Imperial Liquid Gallons



SERVICES

PERFORMANCE, PROFITABILITY, LONGEVITY

DISCOVER OUR SERVICES

MECALAC PREMIUM LUBRICANTS

Premium lubricants to get the best out of your machines:

- Extended machine life
- Extended warranty and extended oil change intervals
- All-weather efficiency



MY MECALAC CONNECTED SERVICES

To optimise the use of its machines, MECALAC offers a range of telematics services:

- Remote fleet management
- Access to all machine usage data of the machines
- Limited machine downtime thanks to preventive maintenance



MECALAC GENUINE PARTS

Only genuine MECALAC parts ensure optimum service life and maximum performance:

- Certified genuine parts
- Maintenance kits
- Extended warranty



MECALAC TRAINING

Make full use of the full potential of your Mecalac machines:

- Efficient use
- Individual coaching
- Intensive practice



MECALAC FINANCIAL SOLUTIONS

A complete range of financial products and associated services to meet your specific needs:

- Machine purchase
- Machine rental
- Competitive rates



WARRANTY EXTENSIONS

Our solutions are well-adapted to your needs to maximise the life of your machines:

- Customised contracts
- Peace of mind
- Controlled expenses



The list of services offered may vary depending on your country. Consult your local Mecalac dealer for details.



SPACE & PANORAMIC VISION



AS600-AS750



AS850-AS1000



TECHNICAL DATA

→ AS600 / 750 / 850 / 1000



TECHNICAL DATA

DATA	AS600	AS750	AS850	AS1000
Operating weight	4400 kg (9,700 lb)	5000 kg (11,023 lb)	6270 kg (13,823 lb)	6640 kg (14,639 lb)
Engine power	36.4 kW / 49.5 hp (48.8 imperial hp)	45 kW / 61.1 hp (60.3 imperial hp)	55.4 kW / 75.3 hp (74.3 imperial hp)	55.4 kW / 75.3 hp (74.3 imperial hp)
Bucket capacity	0.60 m ³ (0.78 yd ³)	0.75 m ³ (0.98 yd ³)	0.85 m ³ (1.1 yd ³)	1 m ³ (1.3 yd ³)
Zero-play, chain operated 180° swing system	•	•	•	•
Comfortable panoramic driver's cabin with ROPS and FOPS safety system	•	•	•	•
Ergonomic joystick control	•	•	•	•
Servo-assisted joystick controls	•	•	•	•
High-performance, power-controlled, hydrostatic four-wheel drive	•	•	•	•
Four-wheel steering system with automatic alignment	•	•	•	•
Planetary axles with self-locking differential on front axle	•	•	•	•
Kinematics	P-Kinematic	P-Kinematic	Z-Kinematic	Z-Kinematic
Excellent parallel lifting characteristics	•	•	•	•
Hydraulically controlled quick-coupler with electric safety feature	•	•	•	•
Wide range of attachments	•	•	•	•

ENGINE	AS600	AS750	AS850	AS1000
EU Stage V - Diesel Particulate Filter (DPF) / U.S. EPA Tier 4 Final*. Low-noise, water-cooled with intercooler. Common Rail injection system, cooled external exhaust gas recirculation, diesel oxidation catalyst (DOC).	DEUTZ TCD 2.2 L3 turbo diesel engine	DEUTZ TCD 2.2 L3 turbo diesel engine	DEUTZ TCD 2.2 L3 turbo diesel engine	DEUTZ TCD 2.9 L4 turbo diesel engine
Net power at acc. to ISO 14396	2300 rpm 36.4 kW/49.5 hp (48.8 imperial hp)	2300 rpm 45 kW/61.1 hp (60.3 imperial hp)	2300 rpm 55.4 kW/75.3 hp (74.3 imperial hp)	2300 rpm 55.4 kW/75.3 hp (74.3 imperial hp)
Max. torque at acc. to ISO 14396	1600 rpm 180 Nm (133 ft.lbf)	1600 rpm 250 Nm (184 ft.lbf)	1600 rpm 280 Nm (206.5 ft.lbf)	1400 rpm 375 Nm (276.6 ft.lbf)
Air intake filter: 2-level dry-air filter with safety cartridge	•	•	•	•
Electrical system: - Operating voltage - Battery capacity - Alternator rating	12 Volt 50 Ah 95 A	12 Volt 50 Ah 95 A	12 Volt 95 Ah 120 A	12 Volt 95 Ah 120 A

*Depending on your Local Legislation - Environmental Protection Agency (EPA)

TECHNICAL DATA

DRIVE	AS600	AS750	AS850	AS1000
Hydrostatic drive with automotive control, stages for maximum propulsive force, shifttable under load, multifunctional lever (joystick) for drive and working hydraulics control	•	•	•	•
Axles: Planetary axles with four-wheel steering for maximum manoeuvrability, self-locking oscillating rear axle	•	•	•	•
Differential lock: self-locking differential in front axle	•	•	•	•
Wheels: - Tyre size - Optional	12.5-18 15.5/55 R18	12.5-18 15.5/55 R18	14.5-20 365/80 R20	14.5-20 405/70 R20
Speeds: - Road gear (optional) (optional) - Field gear	0-20 km/h (0-12 mph) 0-30 km/h (0-18 mph) / 0-5 km/h (0-3.10 mph)	0-20 km/h (0-12 mph) 0-30 km/h (0-18 mph) / 0-5 km/h (0-3.10 mph)	0-20 km/h (0-12 mph) 0-30 km/h (0-18 mph) 0-40 km/h (0-24 mph) 0-5 km/h (0-3.10 mph)	0-20 km/h (0-12 mph) 0-30 km/h (0-18 mph) 0-40 km/h (0-24 mph) 0-5 km/h (0-3.10 mph)
Oscillation: max. oscillation angle	+/-9°	+/-7°	+/-10°	+/-10°

BRAKES	AS600	AS750	AS850	AS1000
Working brakes: 1. Hydrostatic inching brake, acting on all 4 wheels 2. Hydraulically operated disc brake at the front axle, acting on all 4 wheels	• •	• •	• •	• •
Parking brake: - Mechanically activated parking brake, acting on all 4 wheels, with deactivation of the drive - Wet disk brake and SAHR brake for parking brake	•	•	•	•

STEERING	AS600	AS750	AS850	AS1000
Hydrostatic four-wheel steering with 3 steering modes with automatic alignment (four-wheel, front-wheel and crab steer)	•	•	•	•
Max. steering angle	+/-35°	+/-35°	+/-35°	+/-35°
Turning radius, measured over: rear	3185 mm (10'4")	3250 mm (10'7")	3450 mm (11'3")	3450 mm (11'3")

HYDRAULIC SYSTEM	AS600	AS750	AS850	AS1000
Dual-circuit system with gear pumps 1. Working hydraulics circuit (lift/lower, tilt, accessories), and steering (via priority valve); three-way control valve with primary and secondary safeguards	•	•	•	•
Max. operating pressure at 2300 rpm	40 l/min (10.6 gal/min) and 230 bar (3336 psi)	60 l/min (15.9 gal/min) and 230 bar (3336 psi)	84 l/min (22.2 gal/min) and 230 bar (3336 psi)	84 l/min (22.2 gal/min) and 230 bar (3336 psi)
2. Circuit (swivelling) single control valve with primary and secondary protection	•	•	•	•
Max. operating pressure at 2300 rpm	20 l/min (2.4 gal/min) and 200 bar (2900 psi)	20 l/min (2.4 gal/min) and 200 bar (2900 psi)	38 l/min (10.0 gal/min) and 200 bar (2900 psi)	38 l/min (10.0 gal/min) and 200 bar (2900 psi)
Float position for lifting cylinders Cylinder: 2 lifting cylinders 1 tilting cylinder 2 swing cylinders	• • • •	• • • •	• • • •	• • • •

NOTE: METRIC MEASUREMENTS ARE THE CRITICAL VALUES
- 1 Litre = 0.26417 US Liquid Gallons
- 1 Litre = 0.21997 Imperial Liquid Gallons

+ TECHNICAL DATA

PERFORMANCE DATA	AS600	AS750	AS850	AS1000
Bucket position:				
- Crowd angle	45°	45°	45°	45°
- Dump angle top	39°	43°	49°	49°
Lifting force	2000 daN (4496 lbf)	2500 daN (5620 lbf)	4000 daN (8992 lbf)	4000 daN (8992 lbf)
Break out force	2600 daN (5845 lbf)	3350 daN (7531 lbf)	5600 daN (12589 lbf)	5600 daN (12589 lbf)
Thrust force	2900 daN (6519,5 lbf)	3350 daN (7531 lbf)	4500 daN (10116 lbf)	4500 daN (10116 lbf)
Tipping load:				
- std. bucket, max. steered, straight	2220 kg (4895 lb)	2630 kg (5798 lb)	3200 kg (7055 lb)	3600 kg (7936 lb)
- std. bucket, max. steered, 90°-swivelled	2175 kg (4795 lb)	2630 kg (5798 lb)	3150 kg (6945 lb)	3600 kg (7936 lb)
Tipping load and payload on forks:				
Tipping load:				
- max. steered, frontal	1900 kg (4189 lb)	2300 kg (5071 lb)	2560 kg (5643 lb)	3200 kg (7055 lb)
- max. steered, frontal	2200 kg* (4850 lb)*	-	-	-
- max. steered, 90°-swivelled	1700 kg (3748 lb)	2100 kg (4630 lb)	2520 kg (5556 lb)	2900kg (6393 lb)
- max. steered, 90°-swivelled	1800 kg* (3968 lb)*	-	-	-
Payload:				
- max. steered, frontal, even ground	1520 kg (3351 lb)	1840 kg (4056 lb)	1950 kg (4299 lb)	2560 kg (5644 lb)
- max. steered, frontal, even ground	1760 kg* (3880 lb)*	-	-	-
Tipping load	according to ISO 14397			
Payload	according to EN 474-3			

* With additional counterweight

FILLING CAPACITIES	AS600	AS750	AS850	AS1000
Fuel tank	approx. 65 l (17.2 gal)	approx. 65 l (17.2 gal)	approx. 130 l (34.3 gal)	approx. 130 l (34.3 gal)
Hydraulic system with tank	approx. 55 l (14.5 gal)	approx. 55 l (14.5 gal)	approx. 134 l (35.4 gal)	approx. 134 l (35.4 gal)

CHASSIS	AS600	AS750	AS850	AS1000
Rigid, single-frame chassis with rear axle support for maximum stability, especially when working in swivelled position	•	•	•	•
Sealed articulated/oscillated pivot with play-free, chain operated swinging system with constant turning speed and power	•	•	•	•
Operator's cab with flexible four-point mountings for maximum driver comfort and minimum noise levels	•	•	•	•
The servo-assisted joystick controls are smooth, accurate and long lasting	•	•	•	•

NOTE: METRIC MEASUREMENTS ARE THE CRITICAL VALUES
 - 1 Litre = 0.26417 US Liquid Gallons
 - 1 Litre = 0.21997 Imperial Liquid Gallons

+ STANDARD / OPTIONAL

STANDARD FEATURES	AS600 / AS750 / AS850 / AS1000
Amplly dimensioned ROPS and FOPS panoramic comfort cabin with 2 lockable doors	•
Single piece floor mat for easy cleaning	•
Tinted windows	•
Parallel guided windscreen wiper	•
Rear wiper	•
Front and rear screen washing device	•
Heated rear window	•
2 large fold away outside mirrors	•
Tinted roof window	•
Steering column is adjustable in height and inclination	•
Ergonomically adjustable joystick	•
Multiply adjustable driver's seat	•
Safety belt	•
Sun visor	•
Heating and ventilation system with fresh air filter	•
Main battery switch	•
Interior light	•
12 V socket	•
Coat hook	•
Storage pockets in the cabin	•
Intuitive modular control panel with onboard computer for machine monitoring	•
2 driving lights on cabin roof	•
Single key system	•
Hydraulic quick coupler with electric safety device	•
Towing coupling	•
Fastening and lifting points	•
On/Off 1 st auxiliary hydraulics circuit is integrated in the joystick	•
Color scheme: yellow	•
Operator's cabin, axles and wheels: grey	•

OPTIONAL EQUIPMENT	AS600 / AS750 / AS850 / AS1000
30 km/h version	o
40 km/h version	AS850 / AS1000
Wide tires	o
Interior mirror	o
Acoustic back up alarm	o
2 nd auxiliary hydraulics	o
Permanent function for auxiliary hydraulics	o
High performance hydraulic	AS600 / AS1000
Safety valves	o
Boom suspension	o
Bio-degradable oil fill for hydraulic system	o
Pressureless return line	o
Inching speed	o
Lockable differential on rear axle	o
Air-conditioning system	o
Heated outside mirrors	o
Immobilizer	o
Diesel Particulate Filter (DPF) (standard in Europe)	o

EMISSIONS	AS600	AS750 / AS850 / AS1000
Engine: Emissions according to EU-RL 97/68	EU Stage V - Diesel Particulate Filter (DPF) U.S. EPA Tier 4 Final*	
Noise emission:		
- Sound power level LWA ¹	100 dB(A)	100 dB(A)**
- Acoustic power level LpA ²	75 dB(A)	75 dB(A)**
Vibrations:		
- Vibration total value ³	< 2.5 m (8'2")/s ²	< 2.5 m (8'2")/s ²
- Effective vibration level ⁴	< 0.5 m (1'7")/s ²	< 0.5 m (1'7")/s ²

¹ According to 2000/14/EG

² According to ISO 6396

³ According to ISO/TR 25398

⁴ According to ISO/TR 25398

*Depending on your Local Legislation - Environmental Protection Agency (EPA) - ** To be confirmed

**Standard and optional equipment may vary.
Consult your Mecalac dealer for details.**

+ DIMENSIONS

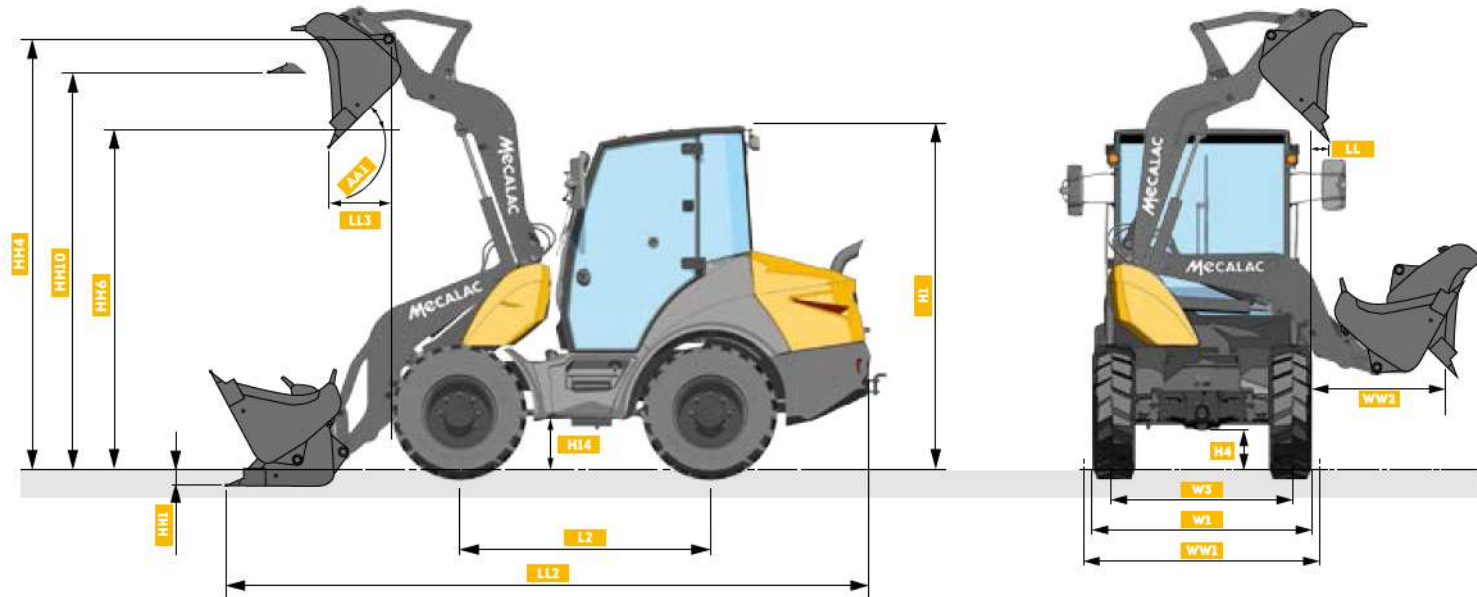

MACHINE DIMENSIONS		AS600	AS750	AS850	AS1000
BUCKET		STD. 0.6 m ³ (0.78 yd ³)	STD. 0.75 m ³ (0.98 yd ³)	STD. 0.85 m ³ (1.11 yd ³)	STD. 1.0 m ³ (1.3 yd ³)
AA1	Tipping angle max	39°	43°	45°	45°
H1	Overall height	2495 mm (8'2")	2495 mm (8'2")	2830 mm (9'3")	2830 mm (9'3")
H4	Ground clearance axles gear box	330 mm (1'1")	330 mm (1'1")	390 mm (1'3.35")	390 mm (1'3.35")
H14	Ground clearance transmission shaft	380 mm (1'2.96")	380 mm (1'2.96")	440 mm (1'5.32")	440 mm (1'5.32")
HH6	Plunge depth	100 mm (0'3.9")	70 mm (0'2.7")	130 mm (0'5.11")	150 mm (0'5.9")
HH4	Bucket pivot pin	3275 mm (10'9")	3300 mm (10'9.9")	3500 mm (11'5")	3500 mm (11'5")
HH6	Dumping height at max lifting height and 45° tipping angle	2600 mm (8'6")	2560 mm (8'5")	2640 mm (8'7")	2650 mm (8'8")
HH10	Loading height at bottom of bucket	2980 mm (9'9")	3105 mm (10'2")	3190 mm (10'5")	3191 mm (10'5")
L2	Wheelbase	1790 mm (5'10")	1870 mm (6'1")	1980 mm (6'5")	1980 mm (6'5")
LL	Side Dumping width at max lifting height and 45° tipping angle	25 mm (0'9.8")	290 mm (0'11.4")	730 mm (2'4")	730 mm (2'4")
LL2	Overall length	4944 mm (16'2")	5010 mm (16'5")	5600 mm (18'4")	5600 mm (18'4")
LL3	Dumping width at max lifting height and 45° tipping angle	415 mm (1'4")	650 mm (2'1.59")	940 mm (3'1")	940 mm (3'1")
W1	Width over tyres	max 1660 mm (5'5") std 1580 mm (5'2")	max 1770 mm (5'9") std 1690 mm (5'6")	std 1950 mm (6'4")	std 1990 mm (6'6")
W3	Wheel track	1290 mm (4'2")	1400 mm (4'7")	1590 mm (5'2")	1660 mm (5'5")
WW1	Width over bucket	1700 mm (5'6")	1860 mm (6'1")	1950 mm (6'4")	2100 mm (6'10")
WW2	Dumping width at min lifting height	1040 mm (3'5")	1225 mm (4'0.22")	1470 mm (4'9")	1470 mm (4'9")

+ DIMENSIONS

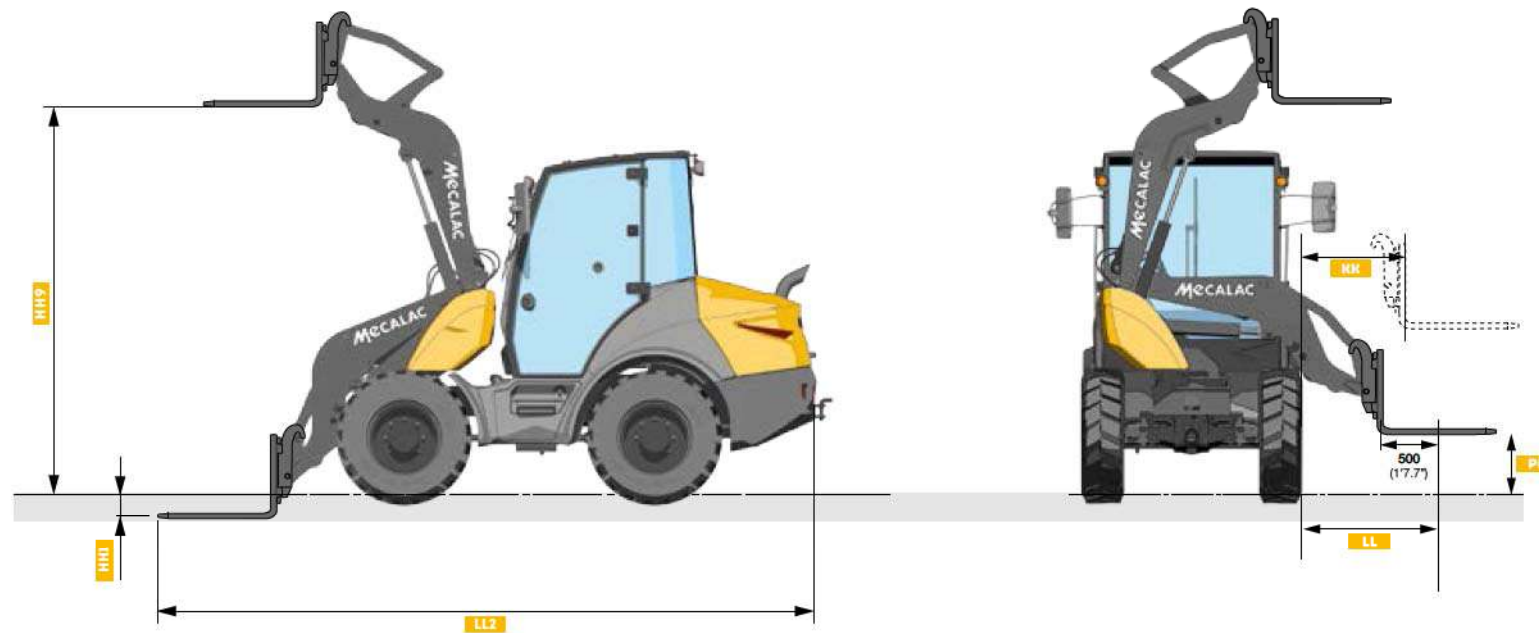

MACHINE DIMENSIONS		AS600	AS750	AS850	AS1000
FORKS					
HH1	Plunge depth	40 mm (0'1.6")	150 mm (0'6")	220 mm (0'8.6")	220 mm (0'8.6")
HH2	Overload height at max. lifting height	3003 mm (9'10")	2780 mm (9'1.45")	3170 mm (12'5")	3170 mm (12'5")
KK	Max load width on the side	762 mm (2'6")	865 mm (2'10")	1010 mm (3'10")	1010 mm (3'10")
LL	Side width of load centre at min lifting height	1122 mm (3'8")	1225 mm (4'0")	1420 mm (5'6")	1420 mm (5'6")
LL2	Overall length	5546 mm (18'2")	5700 mm (18'8")	6160 mm (24'2")	6160 mm (24'2")
PP	Min height on the side	560 mm (1'10")	855 mm (2'9.6")	380 mm (0'1.5")	380 mm (0'1.5")



SWING CONCEPT

Switch to SWING

AS600



CHARACTERISTICS	
Operational weight (kg)	4400 (9,700 lb)
Power (kW/hp)	36.4/49.5 (48.8 imperial hp)
Bucket volume (m ³)	0.6 (0.78 yd ³)

AS900tele



CHARACTERISTICS	
Operational weight (kg)	7250 (15,983 lb)
Power (kW/hp)	55.4/75.3 (74.3 imperial hp)
Bucket volume (m ³)	0.7 - 1.2 (0.92 - 1.6 yd ³)

AS1000 **NEW**



CHARACTERISTICS	
Operational weight (kg)	6640 (14,639 lb)
Power (kW/hp)	55.4/75.3 (74.3 imperial hp)
Bucket volume (m ³)	1.0 (1.3 yd ³)

AS750 NEW



CHARACTERISTICS

Operational weight (kg)	5000 (11,023 lb)
Power (kW/hp)	45/61.1 (60.3 imperial hp)
Bucket volume (m ³)	0.75 (0.98 yd ³)

AS850 NEW



CHARACTERISTICS

Operational weight (kg)	6270 (13,823 lb)
Power (kW/hp)	55.4/75.3 (74.3 imperial hp)
Bucket volume (m ³)	0.85 (1.1 yd ³)

AS1600



CHARACTERISTICS

Operational weight (kg)	10920 (24,074 lb)
Power (kW/hp)	100/136 (134 imperial hp)
Bucket volume (m ³)	1.6 - 2.5 (2.1 - 3.3 yd ³)

AS210



CHARACTERISTICS

Operational weight (kg)	15100 (33,289 lb)
Power (kW/hp)	129/175 (173 imperial hp)
Bucket volume (m ³)	2.1 - 3.0 (2.75 - 3.92 yd ³)

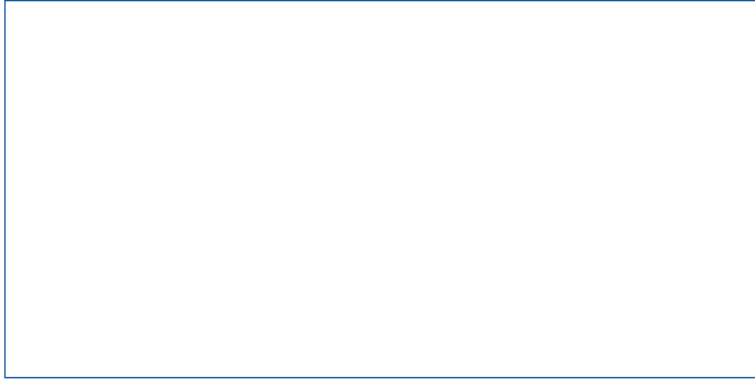

MECALAC FRANCE S.A.S.
2, avenue du Pré de Challes
Parc des Glaisins – CS 40230
Annecy-le-Vieux
FR - 74942 Annecy Cedex
Tel. +33 (0)4 50 64 01 63

**MECALAC BAUMASCHINEN
GMBH**
Am Friedrichsbrunnen
D-24782 Büdelsdorf
Tel. +49 (0)43 31/3 51-319

**MECALAC CONSTRUCTION
EQUIPMENT UK LTD**
Central Boulevard,
ProLogis Park
Coventry, CV6 4BX, UK
Tél. +44 (0)24 7633 9539

**MECALAC İŞ MAKİNELERİ
SAN VE TIC. LTD. ŞTİ.**
Ege Serbest Bölgesi Nilüfer 1 Sok. No: 34
35410, Gaziemir
İzmir - Türkiye
Tel. +90 232 220 11 15



WWW.MECALAC.COM